

Barber Friction Wedge Design Change Notification

Old Design (834-C)

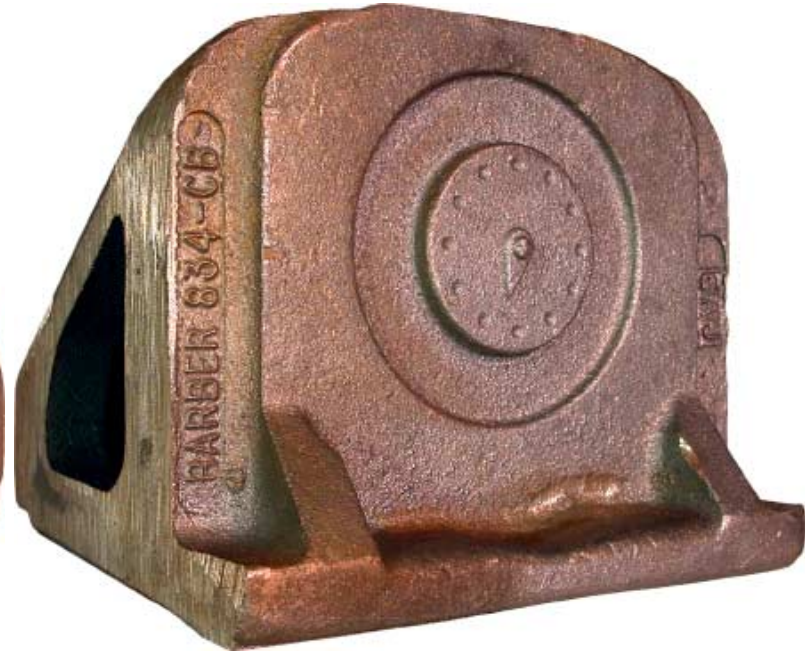

New Design (834-CB)



In an effort to continue to improve on our designs, we have made improvements to our Barber S2-HD Friction Wedge. The 834-CB has a spring boss that will improve the connection to the side spring, while the side spring will assist in keeping the wedge off the sidewalls. We will be implementing the production of the new Barber S2-HD wedge within the next several weeks.

We recently installed numerous 834-CB wedges with no installation problems, so from a manufacturing or repair point, there will be no changes regarding the application. The mixing of 834-C with 834-CB is permissible, as we are aware that many customers will need to utilize existing inventory.

The photos clearly illustrate the difference between the two wedges and we have also included a general arrangement drawing for your review and file.

Please see that this information is passed onto the proper personnel at your organization, and if there are any questions regarding this change please contact your sales representative.



Standard Car Truck Company

865 BUSSE HIGHWAY • PARK RIDGE • ILLINOIS 60068
PHONE: (847) 692-6050 FAX: (847) 692-6299
WWW.SCTCO.COM EMAIL: INFO@SCTCO.COM

STANDARD CAR TRUCK COMPANY RESERVES THE RIGHT TO MODIFY DESIGN OR PROCESSING PROVIDED STRENGTH OR QUALITY IS NOT IMPAIRED.

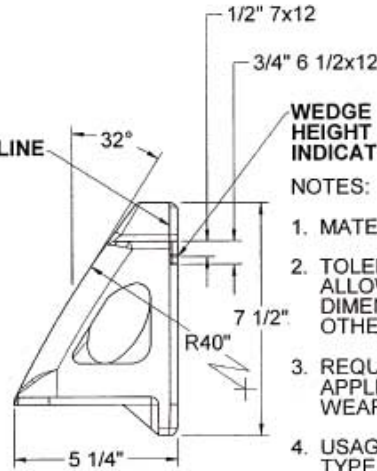
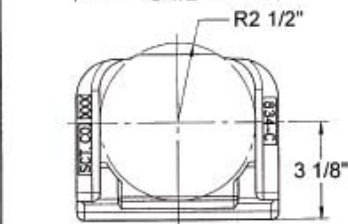
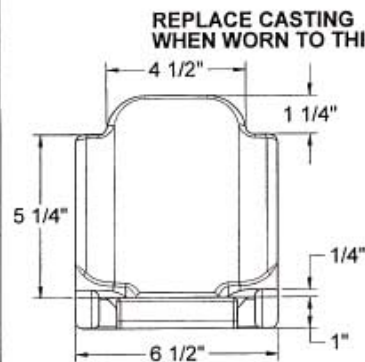
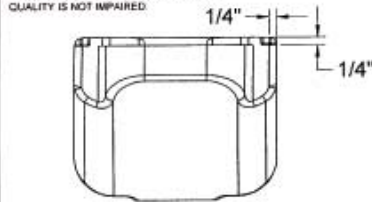

REPLACE CASTING WHEN WORN TO THIS LINE

WEDGE HEIGHT INDICATOR

NOTES:

1. MATERIAL: S.C.T. CO. PATENTED FRICTION IRON.
2. TOLERANCES: FITTING REQUIREMENTS ALLOW TOLERANCES OF $\pm 1/16"$ FOR ALL DIMENSIONS AND DRAFT OF 2° UNLESS OTHERWISE NOTED.
3. REQUIREMENTS: FOR NEW AND RETROFIT APPLICATIONS ON BOLSTERS WITH POCKET WEAR PLATES.
4. USAGE: USED ON BARBER STABILIZED TRUCKS, TYPE S-2-HD, WITH 6 X 11, 6 1/2 X 12, AND 7 X 12 ROLLER BEARINGS. USED ON DOUBLE, B-353 & B-354 SIDE SPRINGS. USED WITH D-5 LOAD SPRINGS. FULLY INTERCHANGEABLE WITH BARBER 834-B FRICTION WEDGE.
5. PATENTS: COVERED BY U.S. PATENTS: 4,084,514; 4,166,756; AND OTHER PATENTS PENDING.

© 1999 STANDARD CAR TRUCK COMPANY, PARK RIDGE, IL 60068 U.S.A. ALL RIGHTS RESERVED. NO PART OF THIS DRAWING MAY BE REPRODUCED, IN ANY FORM OR BY ANY MEANS, WITHOUT THE PERMISSION IN WRITING FROM STANDARD CAR TRUCK COMPANY.

REV	DATE	CHANGES	DRW	CHK	ENG
T	05-06-99	SEE ECH 1386			
S	07-14-99	R 40 WAS 50, 2" WAS 5"			
R	11-01-94	CORE REVISED			
P	09-01-94	CORE OPENING REVISED			
N	10-27-93	CHANGED WEAR INDICATOR AND REDRAWN			

PART NUMBER 834-C		
FRICTION CASTING		
BARBER STABILIZED TRUCK		
PATTERN NO. 834-C		
PROPERTY OF		
STANDARD CAR TRUCK CO.		
PARK RIDGE, IL U.S.A.		
DRW	G.A.	MAR 31 1975
CHK	APR	4734
ENG	SCALE 1:2	SHT 1 OF 1

STANDARD CAR TRUCK COMPANY RESERVES THE RIGHT TO MODIFY DESIGN OR PROCESSING PROVIDED STRENGTH OR QUALITY IS NOT IMPAIRED.

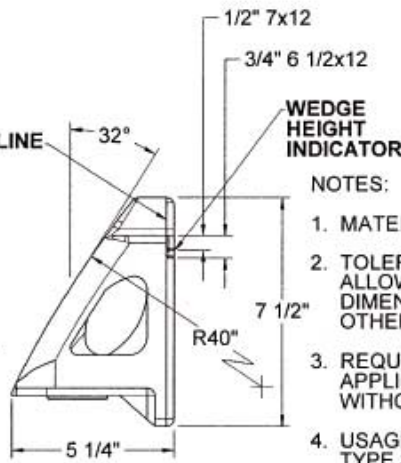
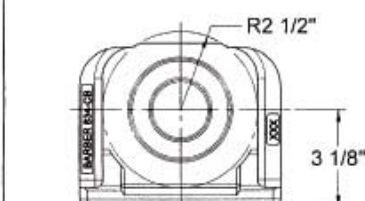
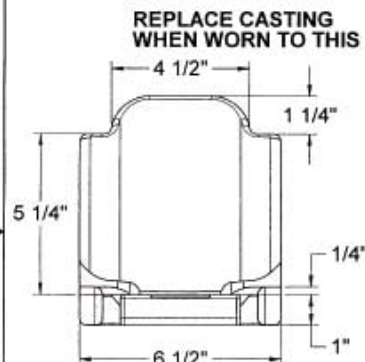
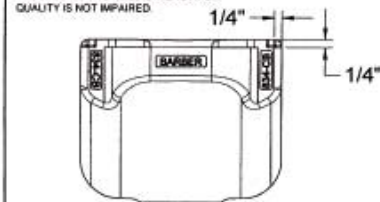

REPLACE CASTING WHEN WORN TO THIS LINE

WEDGE HEIGHT INDICATOR

NOTES:

1. MATERIAL: S.C.T. CO. PATENTED FRICTION IRON.
2. TOLERANCES: FITTING REQUIREMENTS ALLOW TOLERANCES OF $\pm 1/16"$ FOR ALL DIMENSIONS AND DRAFT OF 2° UNLESS OTHERWISE NOTED.
3. REQUIREMENTS: FOR NEW AND RETROFIT APPLICATIONS ON BOLSTERS WITH OR WITHOUT POCKET WEAR PLATES.
4. USAGE: USED ON BARBER STABILIZED TRUCKS, TYPE S-2-HD, WITH 6 X 11, 6 1/2 X 12, AND 7 X 12 ROLLER BEARINGS. USED ON DOUBLE, B-353 & B-354 SIDE SPRINGS. USED WITH D-5 LOAD SPRINGS. FULLY INTERCHANGEABLE WITH BARBER 834-B FRICTION WEDGE.
5. PATENTS: COVERED BY U.S. PATENTS: 4,084,514; 4,166,756; AND OTHER PATENTS PENDING.

© 2000 STANDARD CAR TRUCK COMPANY, PARK RIDGE, IL 60068 U.S.A. ALL RIGHTS RESERVED. NO PART OF THIS DRAWING MAY BE REPRODUCED, IN ANY FORM OR BY ANY MEANS, WITHOUT THE PERMISSION IN WRITING FROM STANDARD CAR TRUCK COMPANY.

REV	DATE	CHANGES	DRW	CHK	ENG
V	01/04/00	SEE ECH 1492			
U	05/17/99	SEE ECH 1393			
T	05-06-99	SEE ECH 1386			
S	07-14-99	R 40 WAS 50, 2" WAS 5"			
R	11-01-94	CORE REVISED			
P	09-01-94	CORE OPENING REVISED			
N	10-27-93	CHANGED WEAR INDICATOR AND REDRAWN			

PART NUMBER 834-CB		
FRICTION CASTING		
BARBER STABILIZED TRUCK		
PATTERN NO. 834-C		
PROPERTY OF		
STANDARD CAR TRUCK CO.		
PARK RIDGE, IL U.S.A.		
DRW	G.A.	MAR 31 1975
CHK	APR	4734
ENG	SCALE 1:2	SHT 1 OF 1

Old Design (834-C)

New Design (834-CB)